



Modular Cooking Range Line thermaline 85 - Full Module Gas Fry Top, 1 Side with Backsplash

ITEM # _____

MODEL # _____

NAME # _____

SIS # _____

AIA # _____

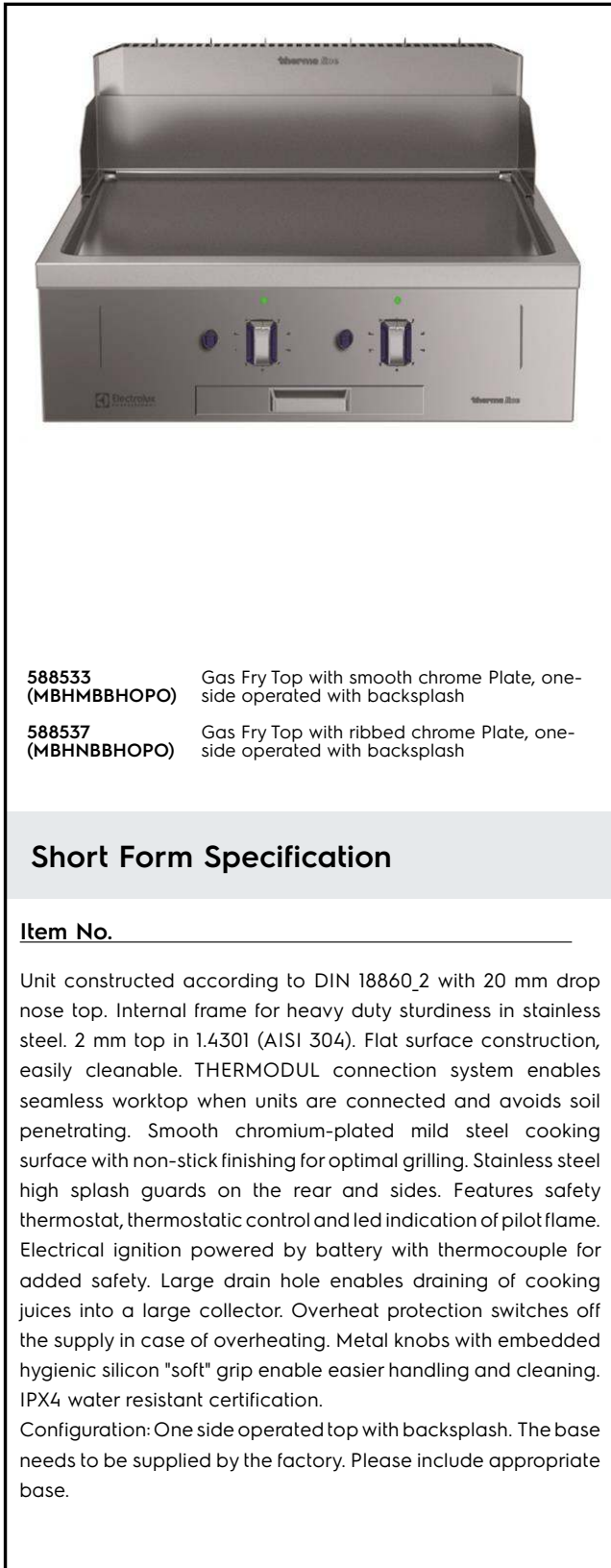

588533 (MBHMBBHOPO) Gas Fry Top with smooth chrome Plate, one-side operated with backslash

588537 (MBHNBBHOPO) Gas Fry Top with ribbed chrome Plate, one-side operated with backslash

Short Form Specification

Item No. _____

Unit constructed according to DIN 18860_2 with 20 mm drop nose top. Internal frame for heavy duty sturdiness in stainless steel. 2 mm top in 1.4301 (AISI 304). Flat surface construction, easily cleanable. THERMODUL connection system enables seamless worktop when units are connected and avoids soil penetrating. Smooth chromium-plated mild steel cooking surface with non-stick finishing for optimal grilling. Stainless steel high splash guards on the rear and sides. Features safety thermostat, thermostatic control and led indication of pilot flame. Electrical ignition powered by battery with thermocouple for added safety. Large drain hole enables draining of cooking juices into a large collector. Overheat protection switches off the supply in case of overheating. Metal knobs with embedded hygienic silicon "soft" grip enable easier handling and cleaning. IPX4 water resistant certification.

Configuration: One side operated top with backslash. The base needs to be supplied by the factory. Please include appropriate base.

Main Features

- Choice of one or two heating zones. An indicator lamp shows operating state of each zone.
- Large drain hole on cooking surface permits the draining of residual cooking juices into a large collector placed under the cooking surface.
- Overheat protection: the temperature sensor switches off the supply in case of overheating.
- Stainless steel high splash guards on the rear and sides of cooking surface.
- Units have separate controls for each half module of the cooking surface.
- All major components may be easily accessed from the front.
- THERMODUL connection system creates a seamless work top when units are connected to each other thus avoiding soil penetrating vital components and facilitating the removal of units in case of replacement or service.
- Metal knobs with embedded hygienic "soft-touch" grip for easier handling and cleaning. The special design of the controls prevents infiltration of liquids or soil into vital components.
- Safety thermostat and thermostatic control.
- Electrical ignition powered by battery with thermocouple for added safety.
- Led indication of pilot flame

Construction

- 2 mm top in 1.4301 (AISI 304).
- Flat surface construction with minimal hidden areas to easily clean all surfaces
- Internal frame for heavy duty sturdiness in 1.4301 (AISI 304).
- Cooking surface in chromium-plated mild steel with non-stick finishing for optimum grilling results.
- Unit constructed according to DIN 18860_2 with 20 mm drop nose top.
- IPx4 water protection.
- Cooking surface to be completely smooth or completely ribbed.

APPROVAL: _____





Optional Accessories

- Connecting rail kit for appliances with backsplash, 850mm PNC 912498
- Back panel, 800x700mm, for units with backsplash PNC 913013
- Endrail kit, flush-fitting, with backsplash, left PNC 913115
- Endrail kit, flush-fitting, with backsplash, right PNC 913116
- Scraper for smooth plates (only for 588533) PNC 913119
- Scraper for ribbed plates (only for 588537) PNC 913120
- Endrail kit (12.5mm) for thermaline 85 units with backsplash, left PNC 913206
- Endrail kit (12.5mm) for thermaline 85 units with backsplash, right PNC 913207
- U-clamping rail for back-to-back installations with backsplash (to be ordered as S-code) PNC 913226
- Insert profile, d=850mm PNC 913231
- Stainless steel side panel (12,5mm), 850x400mm, left side, wall mounted PNC 913632
- Stainless steel side panel (12,5mm), 850x400mm, right side, wall mounted PNC 913633
- Stainless steel side panel (12,5mm), 850x400mm, flush-fitting, left side, wall mounted PNC 913634
- Stainless steel side panel (12,5mm), 850x400mm, flush-fitting, right side, wall mounted PNC 913635
- Wall mounting kit top - TL85/90 - Factory Fitted PNC 913652

Recommended Detergents

- C41 HI-TEMP RAPID DEGREASER, 1 pack of six 1 lt. bottles (trigger incl.) PNC 0S2292

Gas

- Gas Power:** 20 kW
- Gas Type Option:**
- Gas Inlet:** 1/2"

Key Information:

- Cooking Surface Depth:** 615 mm
- Cooking Surface Width:** 700 mm
- Working Temperature MIN:** 110 °C
- Working Temperature MAX:** 270 °C
- External dimensions, Width:** 800 mm
- External dimensions, Depth:** 850 mm
- External dimensions, Height:** 250 mm
- Net weight:** 120 kg
- Configuration:** One-Side Operated;Top
- Cooking surface type:**
 - 588533 (MBHMBBHOPO)** Smooth
 - 588537 (MBHNBBHOPO)** Ribbed
- Cooking surface - material:** Chromium Plated mild steel mirror

Sustainability

- Energy consumption, Min/Max:** 0 - 2.12 m³/h



Electrolux
PROFESSIONAL

**Modular Cooking Range Line
thermaline 85 - Full Module Gas
Fry Top, 1 Side with Backsplash**

Front

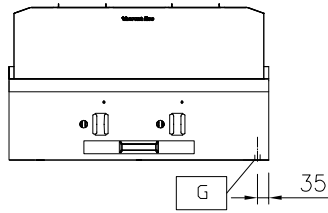

Side

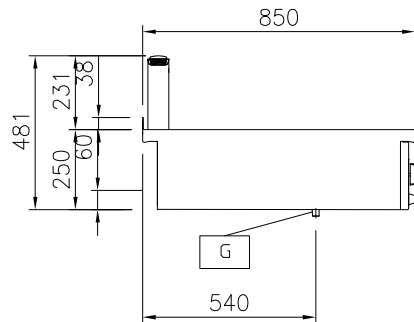

EQ = Equipotential screw
G = Gas connection

Top

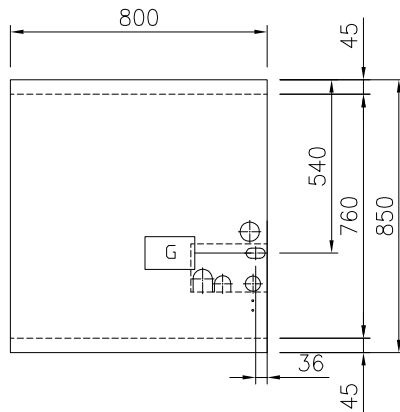

Front

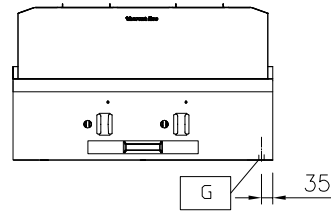

Side

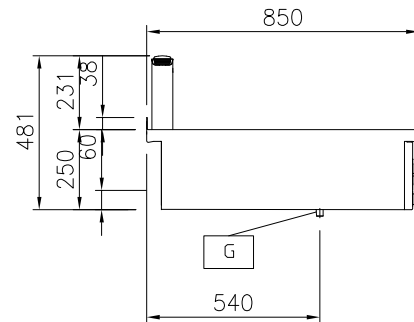

EQ = Equipotential screw
G = Gas connection

Top

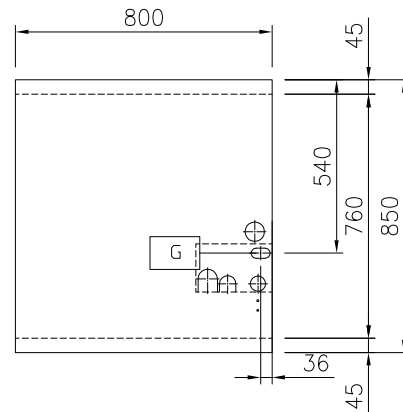

**Modular Cooking Range Line
thermaline 85 - Full Module Gas Fry Top, 1 Side with Backsplash**
The company reserves the right to make modifications to the products
without prior notice. All information correct at time of printing.

2026.05.25